

2016



MOM FRIENDLY. DAD READY.™



Exclusive Sedona Ready to Finish Island Packages are complete, including the island

SEDONA BY LYNX™

MOM FRIENDLY. DAD READY.

All Sedona by Lynx™ products are designed with the family in mind.

Quality materials. Fine craftsmanship. Innovative features and technology. These attributes have earned Lynx products a reputation for excellence among outdoor-dining enthusiasts.

Created by a team with decades of experience meeting the demanding requirements of the commercial restaurant industry, Lynx products have always been designed to combine high performance and luxurious appearance with long-term durability for reliable year-round grilling.

The Lynx commitment to continuous innovation has introduced numerous industry firsts. Including a hood assist kit that makes raising and lowering the grill hood effortless. ProSear infrared burners that allow unprecedented variable temperature control. Advances such as these have made the Lynx name synonymous with the best in outdoor cooking. And they make Sedona by Lynx™ an exceptional value for those in search of much more than an ordinary grill.





SEDONA BY LYNX™ — WELCOME TO A HIGHER STANDARD

In this fast paced, plastic, disposable, and throwaway world, it may seem normal to replace your grill every few years. Rust, decay, and breakage happen, right? Especially if you live in cold winters, hot summers, high humidity, or near salt water. No wonder more than half of all grill purchases were to replace a worn out grill.

The time has come to break this mold: Sedona by Lynx™. With a lifetime warranty against rust, Sedona grills and island accessories are manufactured by the Lynx Grill specialists in Southern California. Combining the latest technology with old world pride, each Sedona grill has the meticulous fit and finish and long lasting materials that have made Lynx the favorite of outdoor kitchen enthusiasts for decades.

Expanding your living space to include your backyard is such a logical step. Everyone wants to be outdoors with nature. We spend too much of our lives indoors. So, friends and family, pull up a chair, relax, and get ready to share a great dining experience outdoors with Sedona by Lynx™.

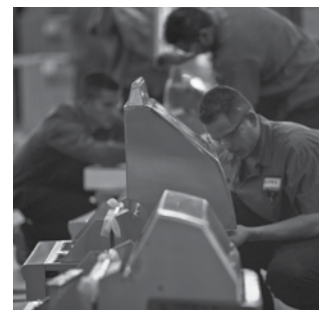

UNIQUE PROSEAR TECHNOLOGY PROVIDES VARIABLE TEMPERATURE CONTROL



PROSEAR VARIABLE SEARING TECHNOLOGY FROM SIMMER TO SEAR

- Unlike many grills with infrared searing burners that only offer two settings – hi or off – the Lynx ProSear infrared burner is variable
- You can sear a baseball-cut filet mignon restaurant style, then throttle back to cook delicate seafood like scallops
- This is the acclaimed ProSear burner for which Lynx has been known for years
- Lifetime Warranty



PROFESSIONAL CHEF FEATURES AND BENEFITS

The innovative features, unparalleled performance and superior craftsmanship of Sedona by Lynx™ Grills are available in 24", 30", 36" and 42" configurations for built-in or freestanding applications.



18-SR STAINLESS STEEL BURNERS

Durable stainless steel tube burners positioned under briquettes ensure instant ignition with steady and even heat distribution

Lifetime Warranty



SUPERIOR FIT AND FINISH

All stainless steel construction

Continuously welded joints for quality, strength and beauty

Finished seams with finely polished edges



CONTROL KNOBS ILLUMINATED WITH BLUE LED LIGHTS

Each knob features dedicated LED lighting

Knob markings can easily be viewed at night

Single switch activation



INTERNAL HALOGEN GRILL SURFACE LIGHT

Effectively illuminates the entire grilling surface using a heavy-duty Pyrex® glass lens directly over the grilling surface

10 watt halogen light

PROFESSIONAL CHEF FEATURES AND BENEFITS



SPARK IGNITION SYSTEM

Reliable spark ignition

Activated by burner control knobs

Battery back-up in event of a power failure



CERAMIC RADIANT BRIQUETTES

Specially designed high-density ceramic

Even heat across the entire grilling surface

Briquettes are clipped in place to facilitate easy reversible cleaning

Enhances food's flavor as drippings hit the briquettes and impart flavor back into the food



STAINLESS STEEL GRATES

Heavy-duty electro-polished stainless steel grates



TEMPERATURE GAUGE

Indicates when your grill is ready for cooking

Large and easy to read

Temperature gauge indicates internal temperature for indirect cooking

PROFESSIONAL CHEF FEATURES AND BENEFITS



INSULATED BULLNOSE

Safe to touch when grill is hot



ROTISSERIE SYSTEM WITH REAR INFRARED BURNER

Rotisserie models include a rear infrared burner

L700 42" Grills - 14,000 BTU

L600 36" Grills - 14,000 BTU

L500 30" Grills - 12,500 BTU

L400 24" Grills - 12,500 BTU



HOOD ASSIST KIT

Heat treated stainless steel spring system

Makes hood operation effortless and safe

Easy to remove for those who appreciate the heft



AMPLE GRILLING SURFACE

24" Grills - 575 square inches (398 primary/177 secondary)

30" Grills - 733 square inches (508 primary/225 secondary)

36" Grills - 891 square inches (618 primary/273 secondary)

42" Grills - 1,049 square inches (728 primary/321 secondary)



Shown
L2600G - Falcon Gray*

L2600G ISLAND WITH 36" GRILL
AVAILABLE IN BOTH COLORS

SEDONA L2500/L2600 ISLAND PACKAGES

Create a fully featured outdoor kitchen in no time at all with a premium Sedona Island Package. Available in two color schemes, and offered with a choice of 30" or 36" grills, these Islands also include an outdoor-rated refrigerator, rotisserie, double side burner and a combination storage system with two fully enclosed pull-out drawers. A 16" overhang along the rear of the island accommodates seating and a circular end counter extension adds extra space for entertaining.



Beautiful detailing throughout



Each island includes two
USB charging ports



Each island includes a pair
of Bluetooth® speakers



16" counter overhang
accommodates seating along the rear

ISLAND PACKAGES - FEATURING 30" & 36" GRILLS



L2600 ISLAND WITH 36" GRILL - *available in both colors*

Model No. L2600G (shown above) / L2600S

BOTH ISLANDS FEATURE

92" x 47" half oval shape with a 47" diameter circular entertainment area feature on the right

16" counter overhang which runs along the back of the island and sweeps around the circular right end to accommodate additional seating

Has two diamond shaped tile features on the back side with a tile kick plate

Welded frame is 1" square tubing with galvanized protection

Premium grade outdoor rated concrete board substrate

Pre-wired with GFI protection for grill and refrigerator connections along with convenient electrical receptacle for rotisserie motor

Two USB charging ports standard

Island comes ready for gas connections and includes required venting

Leveling feet are standard

Tough acrylic stucco which is waterproof, UV resistant and long lasting

Sealed porcelain 6"x 6" tile is unglazed, frost proof, designed for outdoor use

Beautiful cross hatch tile pattern with a 3" border around the counter edges which include a bull nose and 3" vertical lip

Includes a tile border which frames the front of the grill and base on three sides

Includes bluetooth speakers

BOTH ISLANDS INCLUDE

L500REF - 20" outdoor rated refrigerator, 4.1 cu ft. capacity. Includes 3 wire shelves plus door storage and can dispenser in the door. Interior light

LSB502 - Side burner with two 12,500 BTU sealed burners with Blue LED's illuminating the gas control knobs

L2600 ISLANDS INCLUDE

L600 PSR Grill - 36" Grill with (2) 18-SR SS Tube burners and 1 ProSear Burner

LSA636 - Combination storage system with one door and two pull out drawers

L2500 ISLANDS INCLUDE

L500PSR Grill - 30" Grill with (1) 18-SR SS Tube burner and 1 ProSear Burner

LSA530 - Combination storage system with one door and two pull out drawers

ISLAND DIMENSIONS

L2600 - 92 1/8" long x 47 3/16" deep x 40" high

L2500 - 92 1/8" long x 47 3/16" deep x 40" high

ALL ISLANDS ARE AVAILABLE
IN EITHER COLOR SCHEME



***SANDALWOOD**

Beige stucco base with oxy-iron (beige with orange highlights) tile countertop



***FALCON GRAY**

Light gray stucco base with oxy-chrome (dark green with brown highlights) tile countertop

ALL SEDONA ISLANDS ASSEMBLE IN MINUTES

Sedona Islands are designed for easy delivery and quick setup. Delivered in a flat package sized to fit through typical backyard gates, they can be assembled within 30 minutes by two to three people using just a few tools.



SEDONA L1500/L1600 ISLAND PACKAGES

FEATURING 30" & 36" GRILLS

The convenience of an outdoor kitchen is easy to achieve with the essentials built into a classic Sedona Island. Choose from 30" or 36" grill sizes. Your island also includes an outdoor-rated refrigerator and a side burner, as well as doors for extra storage space and a 11" overhang along the rear of the island for seating, so guests can gather around the grill.



*FALCON GRAY

Light gray stucco base with oxy-chrome (dark green with brown highlights) tile countertop



*SANDALWOOD

Beige stucco base with oxy-iron (beige with orange highlights) tile countertop

ALL ISLANDS ARE AVAILABLE IN EITHER COLOR SCHEME



L1500 ISLAND WITH 30" GRILL - *available in both colors*
Model No. L1500G

BOTH ISLANDS INCLUDE

L500REF - 20" outdoor rated refrigerator, 4.1 cu ft. capacity. Includes 3 wire shelves plus door storage and can dispenser in the door. Interior light

LSB501 - Side burner with a 12,500 BTU sealed burner with blue LED illuminating the gas control knob. Standard with stainless steel cover and gas and electrical connections to grill

L1600 ISLANDS INCLUDE

76" x 40" rectangular shape with a 11" counter overhang to accommodate seating along the rear

L600PS Grill - 36" grill with (2) 18-SR stainless steel tube burners and 1 ProSear burner, grill includes internal halogen hood light, blue LED lights over each gas control knob and many other features

LDR636 - 36" double access doors allow access to utility connections below the grill and extra storage

L1500 ISLANDS INCLUDE

71" x 40" rectangular shape with a 11" counter overhang to accommodate seating along the rear

L500PS Grill - 30" grill with (1) 18-SR stainless steel tube burner and 1 ProSear burner, grill includes internal halogen hood light, blue LED lights over each gas control knob and many other features

LDR530 - 30" double access doors allow access to utility connections below the grill and extra storage

ISLAND DIMENSIONS

L1600 - 76 1/8" long x 40 5/8" deep x 40" high

L1500 - 71 3/4" long x 40 5/8" deep x 40" high

L1600 ISLAND WITH 36" GRILL
available in both colors

Model No. L1600S



11" counter overhang accommodates seating along the rear



Each island includes a pair of Bluetooth® speakers



ICE 'N FIRE PITS



FIRE CONVERTS TO REFRESHMENT BOWL

- Includes a 30qt. stainless steel refreshment bowl
- Easily convertible— no tools

MATERIALS

- 2 stainless steel bowls for ice or fire
- 65,000BTU Nautilus stainless steel burner
- T-Handle valve and battery push button spark igniter
- LP to NG Conversion Kit Model no. LFPNGK available for purchase

FINISH

- Available in Sandalwood or Falcon Gray
- Tough acrylic stucco which is waterproof, UV resistant and long lasting
- Sealed porcelain 6" x 6" tile is unglazed, frost proof, designed for outdoor use
- Vinyl cover included

ICE 'N FIRE PITS

available in sandalwood/falcon gray, 48" circular/square top

Model No. LFPC-G/LFPC-S/LFPS-G/LFPS-S

FIRE PIT ASSEMBLY STEP BY STEP PHOTOS



1. Place the base
2. Install the top
3. Place the pan into top
4. Fire Bowl

REFRESHMENT BOWL CONVERSION



1. Remove burner pan from top
2. Place refreshment bowl into top
3. Refreshment bowl



FINALLY, AN AFFORDABLE OUTDOOR KITCHEN SOLUTION

Ready To Finish (RTF) Island comes prepared for the 30" L500 Grill and door drawer combination. 36" and 42" configurations require a few additional cuts by homeowner or contractor to remove additional panels for placement of grill and door drawer combination.

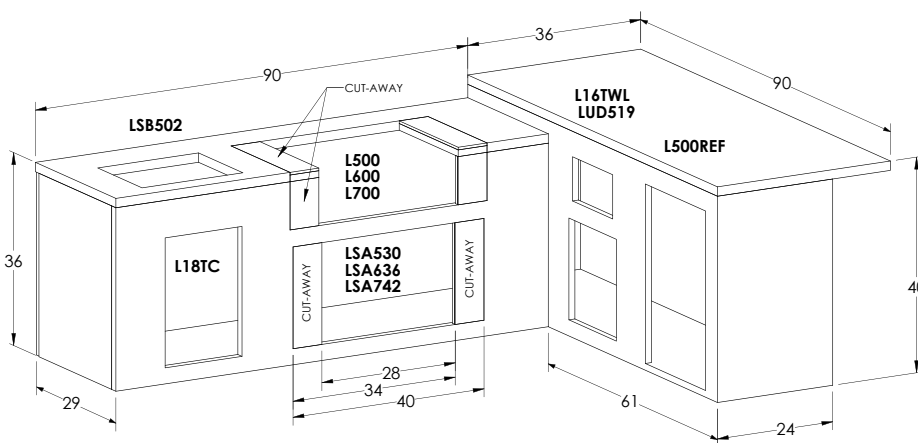

EASE OF ASSEMBLY

The ready to finish island is designed for easy delivery and fast assembly. The island can be assembled within 30 minutes by two to three people.

AFFORDABILITY

Whether you're interested in just the island or in one of the full packages that Sedona by Lynx is offering, this solution will reduce the cost of building an outdoor kitchen by up to 60%.

NO COMPROMISE

The outdoor kitchen is an extension of your home. Finish the island to match the architecture of your home. Choose from a variety of packages and the grill size that suits you.



READY TO FINISH FIREPIT

Finish the firepit to match your backyard and outdoor kitchen.

UNMATCHED QUALITY

Framing made of galvanized steel and hardback board with Mold Block Technology. Each island is handcrafted and backed by a limited lifetime warranty by Lynx Grills.

FLEXIBILITY

Package includes a 30", 36", or 42" Sedona by Lynx grill, door drawer combination (LSA), double side burner (LSB502), trash center (L18TC), paper towel dispenser (L16TWL), double utility drawers (LUD519), and refrigeration (L500REF). Island is fully reversible from "L" left to "L" right.

MODEL	DESCRIPTION
LRTF	Ready To Finish Island
RTFF	Ready To Finish Firepit
L5000	RTF Island: 30" Sedona Grill with Rotisserie – LSA530, LSB502, L16TWL-1, LUD519, L18TC, L500REF
L6000	RTF Island: 36" Sedona Grill with Rotisserie – LSA636, LSB502, L16TWL-1, LUD519, L18TC, L500REF
L7000	RTF Island: 42" Sedona Grill with Rotisserie – LSA742, LSB502, L16TWL-1, LUD519, L18TC, L500REF

NOTE: Must Specify Gas Type – NG for Natural Gas or LP for Propane.

— A GREAT —
**DESIGN
CHANGES
EVERYTHING**



GET STARTED TODAY
With your complimentary design

Visit the Lynx Design Center
www.lynxgrills.com/designservice
designservice@lynxgrills.com



MEET THE PROS



ANDRÉS DANGOND
DOWNEY, CA
LYNX EXECUTIVE CHEF, ONE
OF THE YOUNGEST MICHELIN
EXPERIENCED CHEFS

"The thing that blows my mind every time I turn on a Lynx Grill is how insanely hot it can get in a short amount of time. Realizing how fast it responds to heat adjustments when cooling it down for slow cooking after searing, or quickly heating up for reverse searing, made me realize we can almost forget everything we know about traditional grilling. These machines are perfect."



DEVIN ALEXANDER
LOS ANGELES, CA
MEDIA PERSONALITY, WEIGHT
LOSS EXPERT, CHEF ON NBC'S
THE BIGGEST LOSER

"I grill almost daily because grilling adds amazing flavor without adding the calories! I'm in love with my Lynx because it adds so much versatility and ease with an incredibly upscale look."



DONATELLA ARPAIA
NEW YORK, NY
IRON CHEF JUDGE AND
RESTAURATEUR

"My Lynx outdoor kitchen is beautiful, powerful and uses the latest technology. The grill cooks more evenly than any other grill and the made in America craftsmanship made it the only choice for me. There isn't anything I can't cook outside that I can inside. Our outdoor kitchen has become the heart of our home. It is perfect for entertaining and enjoying the beauty of the lake."



KEVIN GARVIN
DALLAS, TX
EXECUTIVE CHEF, NEIMAN
MARCUS RESTAURANTS

"I like to use my outdoor Lynx grill as often as I can and nothing is better than searing a nice New York steak at 500 to 600 degrees. Once both sides are seared I move the steak to a cooler part of the grill to finish cooking. It's that outside crispy char that I strive for all the time. Thanks for building the greatest grills in the world!"



GLENN LYMAN
CHARLOTTE, NC
PERSONAL CHEF TO HIGH
PROFILE ATHLETES

"When I think about time spent around the grill, I recall a lifetime of experience and quality time with family and friends. I cherish the memories of hanging out around the grill, sharing stories, swapping recipes, and making plans for the next gathering. Imagining the great taste and smell of grilled food sparks up nostalgia I will never forget. Thanks to the championship quality of Lynx, I have a real home-court advantage in the outdoor kitchen!"



MICHAEL SCHWARTZ
MIAMI BEACH, FL
CHEF/RESTAURATEUR

"I'm honored to be part of the Lynx Chef Panel and work with its innovative products. Grilling is one of the simplest ways to build flavor into a dish and has always played an important role in my approach to cooking."



KENT RATHBUN
DALLAS, TX
IRON CHEF RESTAURATEUR

"As a chef I have been fortunate enough to work with many brands of equipment but when it comes to outdoor appliances, I find Lynx to be the Porsche of outdoor kitchen products."



**ELIZABETH BLAU &
KIM CANTEENWALLA**
LAS VEGAS, NV
CHEF/RESTAURATEUR

"We are very proud to be joining the Lynx Chef Panel. Our Lynx grill is a key component to our entertaining success. We truly feel there is no competitor that can hold a candle to Lynx in terms of outdoor grilling."

FREESTANDING MODELS FOR MOBILE CONVENIENCE

Enjoy the advanced grilling technology and superior craftsmanship of Sedona by Lynx™ in a form that fits in any outdoor area—even small patios. Sedona Freestanding models offer a full range of grill sizes and convenience features. They also roll easily on heavy-duty castors so you can quickly reposition your grill or store it when you're not entertaining.

**Grill and Cart Shipped Separately*



42" GRILL

Model No. L700PSR (shown)
with Model No. L700CART

Available Models:
L700F / L700FR / L700PSF / L700PSFR



36" GRILL

Model No. L600PSR (shown)
with Model No. L600CART

Available Models:
L600F / L600FR / L600PSF / L600PSFR



30" GRILL

Model No. L500PSR (shown)
with Model No. L500CART

Available Models:
L500F / L500FR / L500PSF / L500PSFR



24" GRILL

Model No. L400PSR (shown)
shown with Model No. L400CART

Available Models:
L400F / L400FR / L400PSF / L400PSFR

BUILT-IN MODELS FOR OUTDOOR KITCHEN



42" BUILT-IN GRILL

Model No. L700PSR (shown)

ProSear infrared technology delivers intense and controllable infrared heat
 1,049-sq. in. cooking surface (728 primary, 321 secondary)
 (2) 18-SR Stainless steel tube burners for extremely even cooking temperature
 Superior fit and finish - continuously welded joints
 Spark ignition system with battery back-up
 Control illumination with blue LED lights
 Dual internal halogen grill surface lights
 Specially designed high-density ceramic radiant briquettes
 Large and easy-to-read temperature gauge
 Hood Assist Kit
 Optional rotisserie models include rear infrared burner, compact rotisserie motor, spit rod and two spit forks
 Stainless steel grilling grates
 Dimensions - 42"W x 25"D x 25"H
 Available in 4 different burner configurations - L700, L700R, L700PS & L700PSR

MODEL	DESCRIPTION
L700	42" Built-In Grill - 3 Stainless Steel Burners
L700R	42" Built-In Grill - 3 Stainless Steel Burners with Rotisserie
L700PS	42" Built-In Grill - 2 Stainless Steel Burners & 1 ProSear Burner
L700PSR	42" Built-In Grill - 2 Stainless Steel Burners & 1 ProSear Burner with Rotisserie



36" BUILT-IN GRILL

Model No. L600PSR (shown)

ProSear infrared technology delivers intense and controllable infrared heat
 891-sq. in. cooking surface (618 primary, 273 secondary)
 (2) 18-SR Stainless steel tube burners for extremely even cooking temperature
 Superior fit and finish - continuously welded joints
 Spark ignition system with battery back-up
 Control illumination with blue LED lights
 Internal halogen grill surface light
 Specially designed high-density ceramic radiant briquettes
 Large and easy-to-read temperature gauge
 Hood Assist Kit
 Optional rotisserie models include rear infrared burner, compact rotisserie motor, spit rod and two spit forks
 Stainless steel grilling grates
 Dimensions - 36"W x 25"D x 25"H
 Available in 4 different burner configurations - L600, L600R, L600PS & L600PSR

MODEL	DESCRIPTION
L600	36" Built-In Grill - 3 Stainless Steel Burners
L600R	36" Built-In Grill - 3 Stainless Steel Burners with Rotisserie
L600PS	36" Built-In Grill - 2 Stainless Steel Burners & 1 ProSear Burner
L600PSR	36" Built-In Grill - 2 Stainless Steel Burners & 1 ProSear Burner with Rotisserie

BUILT-IN MODELS FOR OUTDOOR KITCHEN



30" BUILT-IN GRILL

Model No. L500PSR (shown)

- ProSear infrared technology delivers intense and controllable infrared heat
- 733-sq. in. cooking surface (508 primary, 225 secondary)
- (1) 18-SR Stainless steel tube burner for extremely even cooking temperature
- Superior fit and finish - continuously welded joints
- Spark ignition system with battery back-up
- Control illumination with blue LED lights
- Internal halogen grill surface light
- Specially designed high-density ceramic radiant briquettes
- Large and easy-to-read temperature gauge
- Hood Assist Kit
- Optional rotisserie models include rear infrared burner, compact rotisserie motor, spit rod and two spit forks
- Stainless steel grilling grates
- Dimensions - 30"W x 25"D x 25"H
- Available in 4 different burner configurations - L500, L500R, L500PS & L500PSR

MODEL	DESCRIPTION
L500	30" Built-In Grill - 2 Stainless Steel Burners
L500R	30" Built-In Grill - 2 Stainless Steel Burners with Rotisserie
L500PS	30" Built-In Grill - 1 Stainless Steel Burner & 1 ProSear Burner
L500PSR	30" Built-In Grill - 1 Stainless Steel Burner & 1 ProSear Burner with Rotisserie



24" BUILT-IN GRILL

Model No. L400PSR (shown)

- ProSear infrared technology delivers intense and controllable infrared heat
- 575-sq. in. cooking surface (398 primary, 177 secondary)
- (1) 18-SR Stainless steel tube burner for extremely even cooking temperature
- Superior fit and finish - continuously welded joints
- Spark ignition system with battery back-up
- Control illumination with blue LED lights
- Internal halogen grill surface light
- Specially designed high-density ceramic radiant briquettes
- Large and easy-to-read temperature gauge
- Hood Assist Kit
- Optional rotisserie models include rear infrared burner, compact rotisserie motor, spit rod and two spit forks
- Stainless steel grilling grates
- Dimensions - 24"W x 25"D x 25"H
- Available in 4 different burner configurations - L400, L400R, L400PS & L400PSR

MODEL	DESCRIPTION
L400	24" Built-In Grill - 2 Stainless Steel Burners
L400R	24" Built-In Grill - 2 Stainless Steel Burners with Rotisserie
L400PS	24" Built-In Grill - 1 Stainless Steel Burner & 1 ProSear Burner
L400PSR	24" Built-In Grill - 1 Stainless Steel Burner & 1 ProSear Burner with Rotisserie

THE SEDONA ADA* COMPLIANT GRILL



Lynx is proud to introduce the first freestanding cart grill designed for individuals with disabilities. Yet another Lynx first, this ADA compliant unit is very accessible, extremely practical and has all the amazing features of the Sedona by Lynx™ Grill. Available in 30" and 36" freestanding cart sizes, with or without rotisserie option.

Meet Michael

The ADA grill is an achievement of passion, vision and a unique partnership that steered the grill's development. When the Lynx engineering team began designing the ADA grill, we knew we needed an authentic voice to guide its development. Through a mutual friend, we were introduced to Michael (out of respect for privacy, we refrain from including his last name). Michael is a C7 quadriplegic, having suffered a break in his 7th cervical spinal cord segment in a diving board accident that left him paralyzed from the chest down.

Michael was involved in shaping key features of the ADA grill; the propane tank holder, the insulated bullnose, and the grill storage system to name a few. We were happy to hear that core features of our Sedona by Lynx grills, such as the Lynx Hood Assist were his favorite features. Michael's contributions on improving the accessibility features of the ADA grill has been invaluable. His insight into the people and families that comprise the disabled community has had impact beyond measure.

We started out as partners. We are glad to call Michael a friend. Thank you for all your contributions Michael. We couldn't have done it without you.

ADA COMPLIANT GRILL

Model No. L500ADA/L500ADAR/L600ADA/L600ADAR

*Americans with Disabilities Act of 1990



LID HANDLE



PROPANE TANK HOLDER



INSULATED BULLNOSE



ADA KNOB



GRILL STORAGE SYSTEM

THE SEDONA BY LYNX™ COLLECTION

All Sedona by Lynx™ Grill Heads can be easily assembled to a matching cart. Carts arrive in a flat package and can be quickly assembled by two people in less than 20 minutes. The unique keyhole slot design provides simple assembly procedure only requiring a screwdriver.



SEDONA BY LYNX™ CARTS FEATURE

Doors with rigid liners

Internal storage shelf

LP tank restraint system

DIMENSIONS

L700 Cart: 42" W x 23" D x 34-7/16" H

L600 Cart: 36" W x 23" D x 34-7/16" H

L500 Cart: 30" W x 23" D x 34-7/16" H

L400 Cart: 24" W x 23" D x 34-7/16" H (single door)



Elegant and Functional Lighting



Superior Craftsmanship



Optional Rotisserie System

COMPLEMENTARY PRODUCTS

Sedona offers a complete line of complementary products to allow you to fully equip your Outdoor Kitchen. This includes a variety of access doors, combination storage systems, side burners, a refrigerator, insulating jackets and vinyl covers. Sedona adaptor kits allow Sedona to fit into a variety of existing island cutouts.



SINGLE ACCESS DOOR

Model No. LDR418 / LDR424

Door has a rigid liner

Easily Installed

Stainless Steel handles

Sized to grill width or for additional storage



DOUBLE ACCESS DOORS

**Model No. LDR530 (30") / LDR636 (36")
LDR742 (42")**

Doors with rigid liners

Easily Installed

Stainless steel handles

Sized to grill width



ACCESS DOOR & FULLY ENCLOSED DOUBLE DRAWERS

**Model No. LSA530 (30") / LSA636 (36")
LSA742 (42")**

Fully enclosed drawers for secure storage

Slides keep drawers solidly in closed position

Stainless steel handles

Sized to grill width

COMPLEMENTARY PRODUCTS



19" ENCLOSED DOUBLE DRAWERS

Model No. LUD519

Each drawer exterior is 19 1/4 wide

Extended depth accommodates oversized items such as grilling tools

Fully extendable drawers on stainless steel slides facilitate smooth and consistent operation



OUTDOOR TRASH CENTER

Model No. L18TC

Provides a concealed, attractive option

Includes heavy-duty removeable trash bin

Tilt out, unframed

Seamless welded construction

Professional style door handles



PAPER TOWEL DISPENSER

Model No. L16TWL-1

Provides a concealed, attractive option

Accommodates a standard roll of paper towels

Heavy duty welded construction

Professional style handle

Door swings up



SINGLE SIDE BURNER

Model No. LSB501

One @12,500 btu burner

Includes stainless steel cover

Blue LED light activated by grill switch

Easy to clean sealed burner base



DOUBLE SIDE BURNER

Model No. LSB502

Two burners @12,500 btu per burner

Includes stainless steel cover

Blue LED lights activated by grill switch

Easy to clean sealed burner base



GRIDDLE PLATE

Model No. GP

Cook anything on your grill

Easy to clean stainless steel surface

11" x 15" cooking surface

Angled 5° slope front to rear to prevent spillage

4 feet firmly grip grates

2" high sides

COMPLEMENTARY PRODUCTS



20" OUTDOOR REFRIGERATOR

Model No. L500REF

- UL listed for outdoor use
- Seamless stainless steel exterior
- Interior light
- 4.1 cubic feet of usable capacity
- 3 wire shelves
- Can dispenser in drawer for convenience
- Additional door storage
- Reversible door (kit included)



18" DROP IN COOLER

Model No. LDC18

- Fully insulated all welded SS cooler with polished highlights
- 1.7 cu. ft. capacity
- Heavy duty refrigerator gasket and insulated lid keeps items cool
- Hydraulic-like bracket holds lid open and allows for soft close action
- Removeable hinge pins allows for cooler to be used without lid
- Drain in base for attaching hose (hose not included)
- 13" depth accommodates most wine bottles



18" DROP-IN SINK

Model No. LSKD18

- Basin size 14 3/4" x 16 1/2" x 10"
- 3 1/2" drain with stopper & basket
- Accommodates disposal unit
- Ice Capacity 18 lbs.
- Sized to accommodate faucet LFK
- Stainless Steel cover included



QUICK DISCONNECT WITH SHUTOFF & FITTINGS

Model No. LQD

- Simple solution for gas connections
- 1/2" ID hose ensures adequate gas supply
- 12' hose includes 1/2" quick disconnect fitting at one end and 1/2" male pipe thread on the other
- Includes manual shut-off valve



INSULATED JACKET

Model No. LIJ700/LIJ600/LIJ500/LIJ400

- Mandatory for grills installed in islands constructed with combustible materials
- Attractive all welded, insulated construction



STAINLESS STEEL FAUCET

Model No. LFK

- Solid stainless steel faucet
- Outdoor rated 10 year warranty
- Hot/cold or cold only
- Washerless operation
- High arch fits larger pots & pans
- Single lever handle operation
- Sleek modern design



VINYL COVER FOR FREESTANDING GRILL

**Model No. VC700F/VC600F/VC500F/VC400F
VC36ADA/VC30ADA**



VINYL COVER FOR BUILT-IN GRILL

Model No. VC700/VC600/VC500/VC400

SPECIFICATIONS & INSTALLATION

The guides, measurements and dimensions detailed below are designated to assist you with planning your outdoor kitchen.

NOTE: Due to continuing product innovation, specifications are subject to change without notice. All measurements are in inches.

IMPORTANT: Please reference the Care & Use / Installation manual for details on gas plumbing requirements, electrical specifications and the proper installation of your Lynx outdoor kitchen equipment. This manual can be downloaded from the Lynx website at www.lynxgrills.com

THE SEDONA BY LYNX COLLECTION

BUILT-IN GRILL

Model	A	B	C
L400	23"	10"	21-1/4"
L500	29"	10"	21-1/4"
L600	35"	10"	21-1/4"
L700	41"	10"	21-1/4"

COMPLEMENTARY PRODUCTS

Model	A	B	C
LSB501*	11"	4"	16"
LSB502*	21"	4"	16"
LDR418	15-5/8"	19"	-
LDR424	22"	19"	-
LDR530	28-1/4"	19"	-
LDR636	33-3/4"	19"	-
LDR742	39-3/4"	19"	-
LSA530	28-1/4"	19"	20"
LSA636	33-3/4"	19"	20"
LSA742	39-3/4"	19"	20"
LUD519	17-1/4"	19"	20"
L16TWL-1	14-1/2"	8-1/4"	8"
L18TC	16"	24-1/4"	13"
L500REF	21-1/2"	34"	24-1/2"
LSKD18	15"	10-1/2"	21"
LDC18	18-1/4"	13"	18-1/4"

BUILT-IN GRILL WITH INSULATING JACKET

Model	A	B	C
LIJ400	30"	11-5/8"	23-1/4"
LIJ500	36"	11-5/8"	23-1/4"
LIJ600	42"	11-5/8"	23-1/4"
LIJ700	48"	11-5/8"	23-1/4"

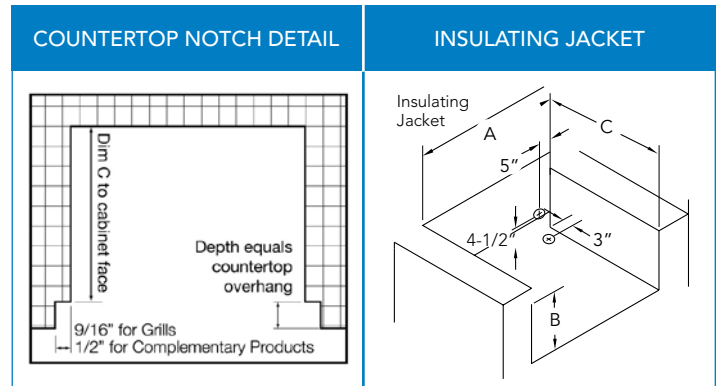
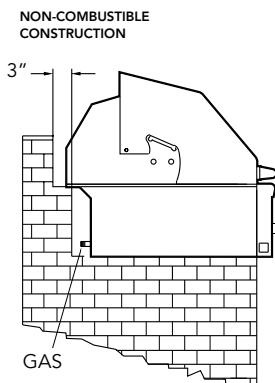

Note: Insulating jacket required for all grills installed into a combustible enclosure.

Note: For Natural Gas grills, Lynx recommends using 3/4" gas lines.

Note: Side burners may be rotated 90 degrees. See installation manuals for details.

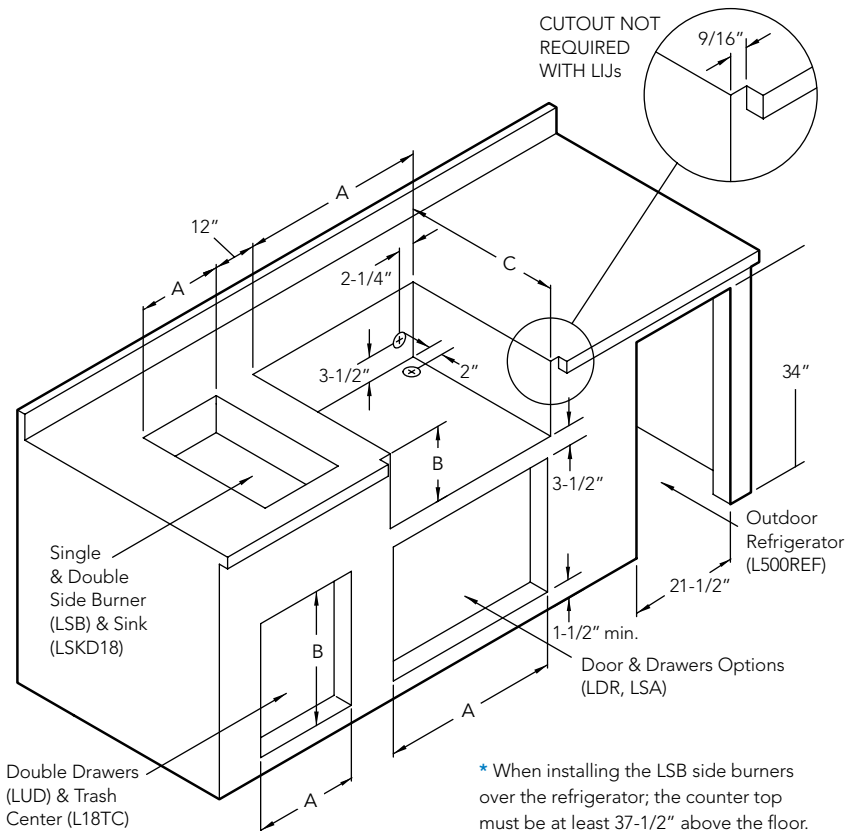

PRODUCT REGISTRATION ONLINE

Go to www.lynxgrills.com/ProductRegistration.asp to register your new Sedona by Lynx™ Grill warranty. The information you provide will not be shared with third parties or individuals without your consent.



The best outdoor kitchen products come from:
Lynx Grills, Inc.
7300 Flores Street
Downey, CA 90242

For more information, please call
1.888.289.5969 or visit www.lynxgrills.com

P/N 35746 03/01/2016 ©Lynx Grills, Inc.



MOM FRIENDLY. DAD READY.™

CONNECT WITH US ONLINE



All Sedona by
Lynx™ Grills

